

Periscopes and the reflection of light

Materials

- Cardboard
- Two square mirrors
- Sticky tape
- Scissors

Procedure

1. Cut two circular holes in a long piece of cardboard (figure 1a).

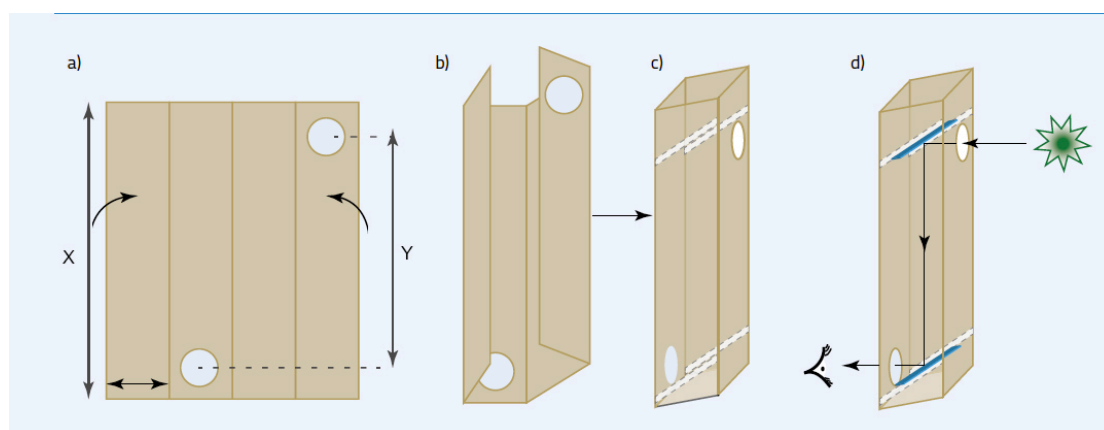

Figure 1: Preparing the cardboard. X: periscope body length; Y: effective length of periscope

Image courtesy of Anand Singh and Tim Saunders

2. Fold the cardboard to form a long, square-sectioned tube (figure 1b) and secure it with sticky tape.
3. At one end of the tube, cut a pair of diagonal slits, one in each of the walls that are at right angles to the circular hole (figure 1c). The slits should be the same distance from the end of the tube and be at the same angle (approximately 45°).
4. Cut a pair of slits at the other end of the tube (figure 1c).
5. Place one mirror in each pair of slits, with the reflective surfaces facing each other. This produces a simple periscope, which students can then enjoy using (figure 1d).

Building a digital microscope

Materials

- Computer
- Webcam with a removable lens
- Simple plastic lens, focal length approximately 10 mm

(If the focal length is not known, it can be simply determined, see below.)

Supporting material for:

Singh A et al (2015) Doing is understanding: science fun in India. *Science in School* 34: 45-51. www.scienceinschool.org/2015/issue34/india

- Plastic or metal washer, with an internal diameter slightly smaller than plastic lens and an external diameter slightly larger
- Two plastic plumbing tubes of equal diameter that screw together, with a similar external diameter to the washer
- Clamp stand with two clamps
- Transparent plastic board as a sample mounting unit
- Instant glue
- Small LED torch
- Glass microscope slides

Where appropriate, further details of the components are in table 1.

Safety note: Do not look directly at any bright objects through the lens.

Assembling the microscope

1. Carefully unscrew and remove the front webcam lens, which is not needed to build the microscope.
2. Attach the plastic lens (figure 2A) to the washer (figure 2B) with instant glue.

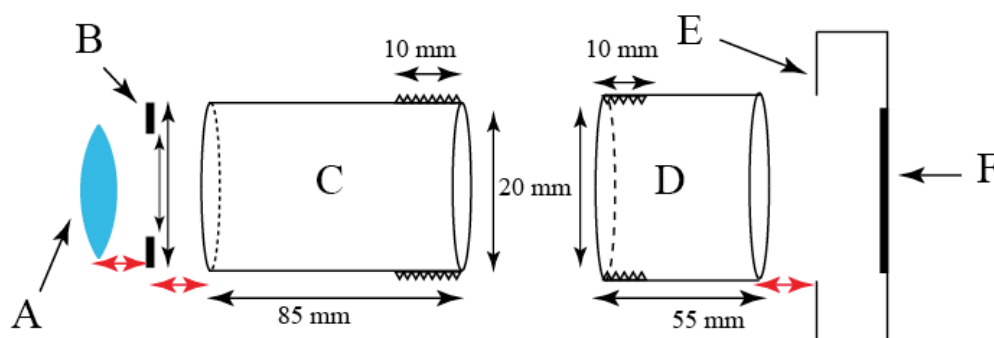

Figure 2: Assembling the microscope. A: lens; B: washer; C: 'male' tube; D: 'female' tube; E: webcam body; F: image sensor. All surfaces to be glued are indicated by red arrows.

Image courtesy of Anand Singh and Tim Saunders

3. Glue the washer (figure 2B) to the non-screw end of the 'male' plastic tube (with the screw thread on the outside, figure 2C).
4. Glue the 'female' plastic tube (with the screw thread on the inside, figure 2D) length onto the webcam body (figure 2E). Take care not to touch the image sensor (figure 2F).
5. Once the glue has set, screw the two tubes together carefully. By screwing the tubes more or less tightly together, you can change the length of the overall tube.
6. Use the clamp stand and the top clamp to support the microscope body (figure 3).

Supporting material for:

Singh A et al (2015) Doing is understanding: science fun in India. *Science in School* 34: 45-51. www.scienceinschool.org/2015/issue34/india

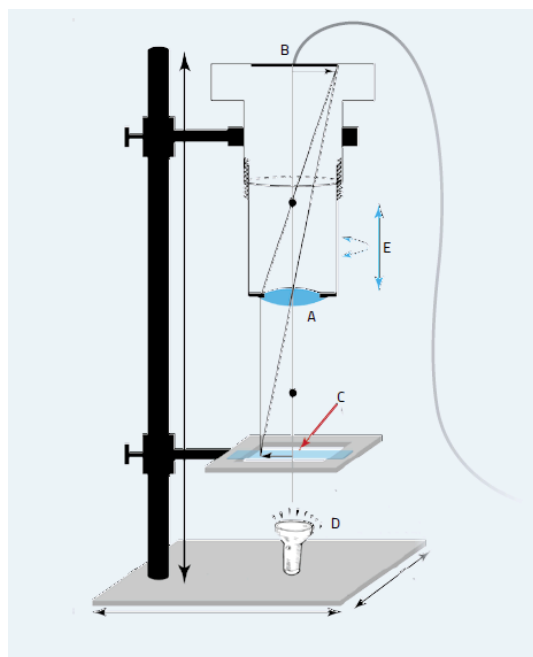

Figure 3: Supported by a clamp stand, the homemade microscope consists of a plastic tube with a lens (A) attached to one end and a webcam (B) to the other, attached to a computer. The sample (C) is clamped in place below the lens and a torch (D) is shone on it. The image can be zoomed by lengthening or shortening the tube (E). Image courtesy of Anand Singh and Tim Saunders

7. Use the lower clamp to attach the transparent sample mounting unit (figure 3C)
8. Once the microscope body is stable, use the USB plug of the webcam to connect it to your computer and install the webcam software to obtain the images.
9. Place a sample on the sample mounting unit, shine the LED torch (figure 3D) onto the sample, then focus and zoom the image (figure 3E), as described below. If the torch has an adjustable power knob, use this to adjust the brightness.

Specification of components

Table 1: Materials required for the digital microscope

| Items | Specification | Example: company and serial no | Other options | Approximate price (€) |
|------------------------------|---------------------------------------|------------------------------------|---|-----------------------|
| Computer | 1–4 GB RAM, approx. 10 GB disk space | -- | Use personal computer or school laboratory computer | |
| Webcam (with removable lens) | ~ 2-30 megapixel | Intex Panther or Intex 400k webcam | Online or local electronic store | 3–20 |
| Plastic lens | 6.25 mm diameter, focal length ~10 mm | Thorlabs CAW110 or APL0609 | Lens from disposable camera | 10–20 |
| Washer | Plastic or metal, 20 mm across, with | -- | Local plumber shop or cut from | 1–2 |

Supporting material for:

Singh A et al (2015) Doing is understanding: science fun in India. *Science in School* 34: 45-51. www.scienceinschool.org/2015/issue34/india

| | | | | |
|---------------------------------------|--|----|--------------------------------|----------------|
| | hole diameter 5.5 mm | | cardboard | |
| Plastic plumber tube 1, to fit tube 2 | Length 85 mm, external thread length ~10 mm, external tube diameter no less than 20 mm | -- | Local plumber shop | 2-5 |
| Plastic plumber tube 2, to fit tube 1 | Length 55 mm, internal thread length ~10 mm, external tube diameter no less than 20 mm | -- | Local plumber shop | 2-5 |
| Clamp stand with two clamps | | | Available in most schools | Not applicable |
| Transparent plastic board | 70 mm x 70 mm x 4 mm | | Local plumber shop | 5 |
| Instant glue | | | Stationery shop or supermarket | 2-5 |
| Small LED torch | | | Electrical shop or supermarket | 5 |
| Glass microscope slides | | | Available in most schools | Not applicable |

Adjusting the microscope

If the image is blurry, move the sample mounting unit closer to or further away from the lens until the image is in focus, then fix the unit in this position using the clamp. (For suggested distances from the lens for the object and the image, together with the resulting magnification, see table 2, below).

To zoom in or out, loosen or tighten the lens tube. The focus may then need to be adjusted, as described above.

If the contrast on your sample is poor, try changing the angle at which you hold the LED torch.

Measuring the focal length of a convex lens

For the digital microscope project, you will need a convex lens with a focal length of around 10 mm. The focal length of a thin convex lens is the distance from the lens at which a parallel beam of light (light coming from a distant object like the Sun) is brought to a focus (f in figure 4).

Supporting material for:

Singh A et al (2015) Doing is understanding: science fun in India. *Science in School* **34**: 45-51. www.scienceinschool.org/2015/issue34/india

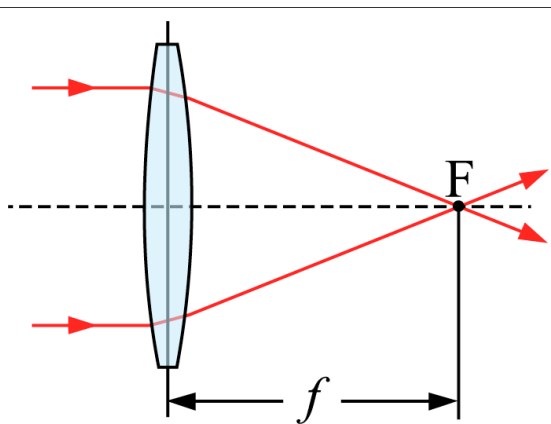

Figure 4: Ray diagram of a convex lens focusing a parallel beam of light, showing the focal point (F) and the focal distance (f)

Image courtesy of DrBob; image source: Wikimedia Commons

This is calculated using the thin lens equation:

$$\frac{1}{f} = \frac{1}{d_o} + \frac{1}{d_i} \tag{Equation 1}$$

where f is the focal length of lens, d_o is the object distance and d_i is the image distance.

In the case of our microscope, d_o is the distance between the lens edge and the sample mount, and d_i is the distance between the lens and webcam sensor (see figure 5); both can be easily measured with a ruler.

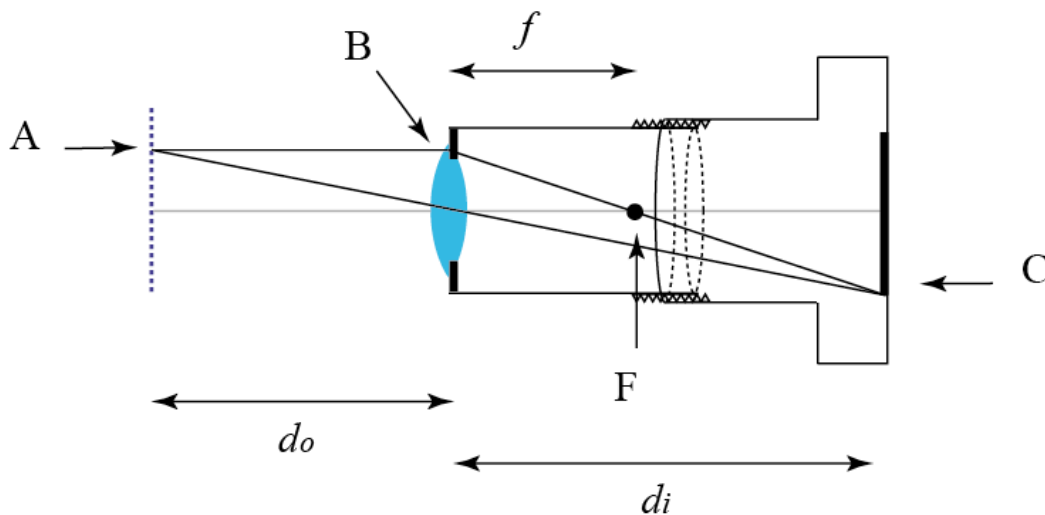

Figure 5: Image formation by our digital microscope. A: sample mount; B: lens; C: image; F: focal point; f: focal length; d_o : object distance; d_i : image distance (d_i)
Image courtesy of Anand Singh and Tim Saunders

The approximate focal length of a convex lens can also be simply measured.

1. Hold the lens by its edges so that light from the Sun passes through it.

Supporting material for:

Singh A et al (2015) Doing is understanding: science fun in India. *Science in School* 34: 45-51. www.scienceinschool.org/2015/issue34/india

2. Hold up a piece of paper on the other side of the lens, and focus the parallel beam of light onto the paper, so that it forms a small bright spot on the paper.

Safety note: Do not look directly at the Sun as this may damage your eyes.

3. Measure the approximate focal length from the surface of the lens to the focused point on the piece of a paper using a ruler.

If we know the distances of the object and the image from the lens, we can also work out the magnification produced by the lens :

$$M = \frac{d_i}{d_o} \quad \text{Equation 2}$$

where M is the magnification, d_o is the object distance and d_i is the image distance and M is the magnification.

Approximate magnification levels with your microscope

Table 2 shows the magnification obtained from a lens with focal length 10 mm for different object and image distances.

Table 2: Estimated magnification for different values of d_o and d_i

| Lens focal length (f , mm) | Object distance (d_o mm) | Image distance (d_i mm) | Magnification (d_i/d_o) |
|-------------------------------|-----------------------------|----------------------------|-----------------------------|
| 10 | 10.8 | 135 | 12.5 |
| 10 | 11 | 110 | 10 |
| 10 | 11.2 | 93.3 | 8.3 |
| 10 | 11.4 | 81.4 | 7.1 |

Gas laws

Demonstrating Boyle's law using balloons

Boyle's law states that, at a constant temperature, the pressure of a fixed amount of gas changes inversely with its volume. This relationship can be easily demonstrated using a large transparent syringe (available from medical stores) and small air balloons.

This experiment takes around one hour and is suitable for students over 10 years old.

Safety note: Hot water can cause injury.

Materials

- Inflatable balloons
- Hot water and water at room temperature
- Two empty plastic bottles
- A large (60-150 ml) plastic syringe
- Two water tubs

Supporting material for:

Singh A et al (2015) Doing is understanding: science fun in India. *Science in School* **34**: 45-51. www.scienceinschool.org/2015/issue34/india

Procedure

1. Partially blow up a small balloon and seal it by tying the end in a knot.
2. Put the inflated balloon inside the syringe (the balloon should be smaller than the syringe diameter).
3. Cover the syringe tip with one hand and push the plunger in with the other hand. The balloon should shrink.
4. Now perform the opposite experiment: pull the plunger outwards, still keeping the syringe tip covered. The balloon should increase in size.

When the plunger is pushed in, the pressure inside the (blocked) syringe increases, causing the volume of the gas inside the balloon to decrease, so the balloon shrinks. The opposite occurs when the plunger is pulled outwards: the pressure inside the syringe decreases, so the balloon expands.

The experiment can be repeated with a water balloon, where the different compressibilities of water and air make the results quite different.

Additional experiments performed in the science workshops

The details of further activities performed at the science workshops are outlined below.

Chemistry

These simple experiments taught the students about different types of reactions and chemical properties. Mixing potassium permanganate and glycerol is particularly exciting because it is a strongly exothermic (explosive) reaction.

- What happens when you mix Coca Cola® and Mentos® (a brand of mint-flavoured sweets)?

Instructions and an explanation of the experiment ('exploding soda') are available on the Science Theatre website: www.sciencetheatre.org. YouTube has many videos demonstrations: www.youtube.com

- What happens when potassium permanganate (KMnO_4) and glycerol are mixed?

Instructions and a video are available on the website of the department of chemistry at the University of Washington (<http://depts.washington.edu/chem>) or use the direct link: <http://tinyurl.com/or5mtbj>

Alternatively, visit the website of the University of New Mexico (www.nmsu.edu) or use the direct link: <http://tinyurl.com/p5xguo5>

- Making an acid-base and pH indicator

See the Middle School Chemistry website (www.middleschoolchemistry.com) or use the direct link: <http://tinyurl.com/pl9ecea>

Alternatively, see the 'red cabbage lab' on the Stanford University website (www.stanford.edu) or use the direct link: <http://tinyurl.com/nfth4f2>

Supporting material for:

Singh A et al (2015) Doing is understanding: science fun in India. *Science in School* **34**: 45-51. www.scienceinschool.org/2015/issue34/india

Physics

- Conservation of energy and momentum. We used a gyroscope to explain – in a fun way – a lot of physical laws, especially to do with conservation of angular momentum and energy.

See the gyroscope video on the Science Kids website (www.sciencekids.co.nz) or use the direct link: <http://tinyurl.com/ojbhpn>

For an explanation of the physics of a gyroscope, visit the Real World Physics Problems (www.real-world-physics-problems.com) or use the direct link: <http://tinyurl.com/q9srpmx>

- Magnetism and electricity: building a magnetic motor. We used objects commonly found around the house to make a simple electromagnet motor.

For many ideas of how to build a motor from simple materials, see the Toys from Trash website (www.arvindguptatoys.com/motor-and-generator.php).

- Force and motion: straw spinner. We used normal drinking straws to demonstrate how force is exerted and how it leads to the motion of an object. This also helps students to understand Newton's third law of motion: that every action has an equal and opposite reaction.

Instructions and a video are available on the Toys from Trash website (www.arvindguptatoys.com/toys/sspinner.html).

- Sound waves: a paper cup and string telephone. This experiment demonstrated how sound travels through a medium.

Full instructions for building a string telephone are available on the Scientific American website (www.scientificamerican.com) or via the direct link: <http://tinyurl.com/pg4ywlf>

Biology

- Immunology: fighting infection. In this demonstration, we used finger puppets to explain the role of white blood cells and immunogens in maintaining human health, showed the children how the human immune system works and how it acts as a successful protective barrier.

The puppet activity was our own invention but the Science Learning website offers a range of activities about the immune system. See <http://sciencelearn.org.nz/Contexts/Fighting-Infection/Teaching-and-Learning-Approaches> or use the direct link: <http://tinyurl.com/p8rbqjl>

- Learning about eco-systems and making a terrarium. This demonstration involved extensive discussion on our ecosystem and its importance, after which the children enjoyed making their own closed terrarium.

Instructions are available on NASA's Climate Kids website (<http://climatekids.nasa.gov/mini-garden>).

Supporting material for:

Singh A et al (2015) Doing is understanding: science fun in India. *Science in School* 34: 45-51. www.scienceinschool.org/2015/issue34/india